



SIGN LIGHTING AUSTRALIA
web: signlighting.com.au

Noel Symon
Ph 07 5564 9930
email: sales@signlighting.com.au



suppliers of Acrylic Edge-Lighting systems and LED lighting for signage

Product Features:

Part Number: 4815W3B



- 1) 3528 SMD Everlight as the light source- A super Luminous Flux
- 2) Large Viewing angle with even light shadow $\geq 120^\circ$
- 3) Lower Light decay and longer life span up to 50,000 hrs
- 4) Lower Cost / High performance & color uniformity
- 5) Low operating Voltage, energy saving, and environmentally friendly
- 6) Suitable for Backlighting channel letters and Light boxes.
- 7) Suitable for Accent and Edge Lighting
- 8) Waterproof: > IP65
- 9) Easy installation and maintenance free

No' of LEDs per sq Meter

Depth of Light-box	Quantity P/Meter ²
80~120mm	96 pcs
130~160mm	50 pcs
170~250mm	30 pcs

Specification:

LED Type:	smd 3528 Everlight - specially designed for Outdoor use
Colour:	White

Luminous Flux (lm / LED)

Red	Green	Blue	Yellow	White	Warm White
3	6	1.5	3	7~8 / 24	6~7

Colours available

R / G / B / Y / WW (special order times apply)

Wavelength Scope (nm)

Color Temp (kelvin)

Red	Green	Blue	Yellow	White	Warm White
619~635	512~528	463~475	584~595	5500K ~ 6500K	2800K~3500K

Match to Power Supply-12V:

≤ 56 pcs	18W
≤ 98 pcs	30W
≤ 193 pcs	60W
≤ 322 pcs	100W
≤ 483 pcs	150W
≤ 644 pcs	200W

Light Angle ($2\theta_{1/2}$):	$\geq 120^\circ$
No' of LEDs per Module	3
Working Voltage:	12V DC
Power:	Max power use = .24 / module - 4.8 W / chain
Driving method:	Constant Voltage
Wires:	Grey: Positive; White: Negative
No' of modules / chain:	20
Max no' modules in series	25
Length of Chain:	2.5 Metres
Distance between modules:	7.5 cm
Shell Material:	ABS grease white
Module dimensions:	48mm(L)* 15mm(w)* 8mm(H)
Installation:	Screw / 3M double sided tape: 45mm(L)*12mm(W)*0.2mm
Working Temp:	-40°C ~+60°C
Storage Temp:	-50°C ~+80°C
IP Rating:	Waterproof - IP65
Warranty:	5 Years / 35,000 hours

RoHS

VO Classified
UL Listed

CE

Age Tested
Caution: ESD sensitive

Module dimensions: (unit: mm)

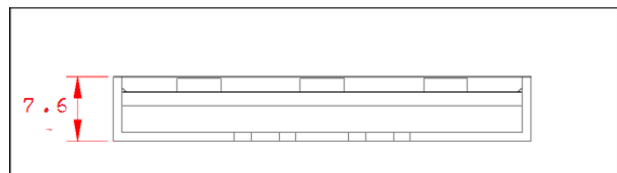
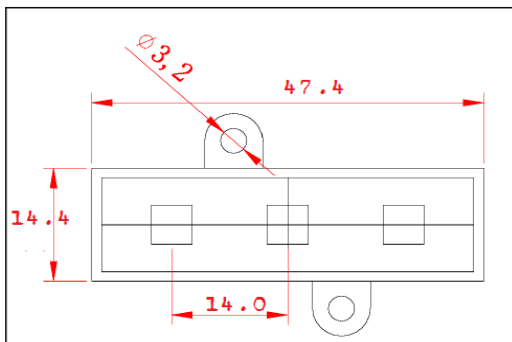

For more information visit: www.Signlighting.com.au