



SIGN LIGHTING AUSTRALIA
web: signlighting.com.au

Noel Symon
Ph 07 5564 9930
email: sales@signlighting.com.au



suppliers of Acrylic Edge-Lighting systems and LED lighting for signage

Product Features:

Part Number: **7220W3A**



Colours available

R / G / B / Y / WW (special order times apply)

Match to Power Supply-12V:

| | |
|-----------|------|
| ≤ 25 pcs | 30W |
| ≤ 50pcs | 60W |
| ≤ 85 pcs | 100W |
| ≤ 125pcs | 150W |
| ≤ 150 pcs | 200W |

- 1) 2835 OSRAM as the light source- A super Luminous Flux
- 2) Large Viewing angle with even light shadow 180 degrees
- 3) Lower Light decay and longer life span up to 50,000 hrs
- 4) Lower Cost / High performance & color uniformity
- 5) Low operating Voltage, energy saving, and environmentally friendly
- 6) Suitable for Backlighting channel letters and Light boxes.
- 7) Suitable for Accent and Edge Lighting
- 8) Waterproof: > IP67
- 9) Easy installation and maintenance free

Specification:

| | | | | | |
|------------------------------|---|---------|--------------------------------|---------------|-------------|
| LED Type: | smd 2835 OSRAM - specially designed for Outdoor use | | | | |
| Colour: | White | | | | |
| luminosity (mcd/LED) | | | Luminous Flux (L / LED) | | |
| Red | Green | Blue | Yellow | White | Warm White |
| 900~1100 | 1400~1600 | 500~600 | 700~900 | 7.5~8 / 42 | 6.5~7 |
| Wavelength Scope (nm) | | | Color Temp (kelvin) | | |
| Red | Green | Blue | Yellow | White | Warm White |
| 619~635 | 512~528 | 463~475 | 584~595 | 6000K ~ 7000K | 2800K~3500K |

| | |
|---------------------------|---|
| Light Angle (2θ ½): | 180° |
| No' of LEDs per Module | 3 OSRAM chips |
| Working Voltage: | 12V DC |
| Power: | Max power use = .095/ module - 22W / chain |
| Driving method: | Constant Voltage |
| Wires: | Grey: Positive; White: Negative |
| No' of modules / chain: | 20 |
| Max no' modules in series | 25 |
| Length of Chain: | 4M |
| Distance between modules: | 20cm |
| Shell Material: | ABS grease white |
| Module diamensions: | 72mm(L)* 20mm(w)* 10.2mm(H) |
| Installation: | Screw / 3M double sided tape: 75mm(L)*12mm(W)*0.2mm |
| Working Temp: | -40°C ~+60°C |
| Storage Temp: | -50°C ~+80°C |
| IP Rating: | Waterproof - IP65 |
| Warranty: | 5 Years / 35,000 hours |

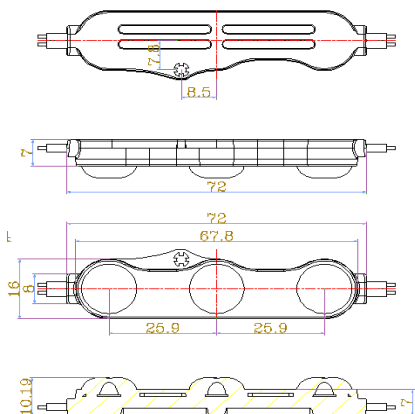

| |
|-------------|
| RoHS |
| CE |

VO Classified
UL Listed
Age Tested
Caution: ESD sensitive

For more information visit: www.Signlighting.com.au